

Candidate Name	Centre Number	Candidate Number

WELSH JOINT EDUCATION COMMITTEE
General Certificate of Secondary Education



CYD-BWYLLGOR ADDYSG CYMRU
Tystysgrif Gyffredinol Addysg Uwchradd

241/02

ADDITIONAL SCIENCE
HIGHER TIER (Grades D-A*)
PHYSICS 2

A. M. FRIDAY, 15 June 2007

(45 minutes)

For Examiner's use only	
Total Marks	

ADDITIONAL MATERIALS

In addition to this paper you may require a calculator.

INSTRUCTIONS TO CANDIDATES

Write your name, centre number and candidate number in the spaces at the top of this page.

Answer **all** questions.

Write your answers in the spaces provided in this booklet.

INFORMATION FOR CANDIDATES

The number of marks is given in brackets at the end of each question or part-question.

You are reminded of the necessity for good English and orderly presentation in your answers.

A list of equations is printed on page 2 of the examination paper. In calculations you should show all your working.

No certificate will be awarded to a candidate detected in any unfair practice during the examination.

EQUATIONS

$$\text{voltage} = \text{current} \times \text{resistance}$$

$$\text{current} = \frac{\text{power}}{\text{voltage}}$$

$$\text{speed} = \frac{\text{distance}}{\text{time}}$$

$$\text{acceleration} = \frac{\text{change in speed}}{\text{time}}$$

$$\text{resultant force} = \text{mass} \times \text{acceleration}$$

$$\text{work} = \text{Force} \times \text{distance}$$

$$\text{kinetic energy} = \frac{\text{mass} \times \text{speed}^2}{2}$$

$$\begin{array}{l} \text{change in potential} \\ \text{energy} \end{array} = \text{mass} \times \begin{array}{l} \text{gravitational field} \\ \text{strength} \end{array} \times \begin{array}{l} \text{change in} \\ \text{height} \end{array}$$

Answer **all** questions.

1. The diagram shows an electric iron.
R, S and **T** are the wires of the cable which connects the iron to the mains plug.

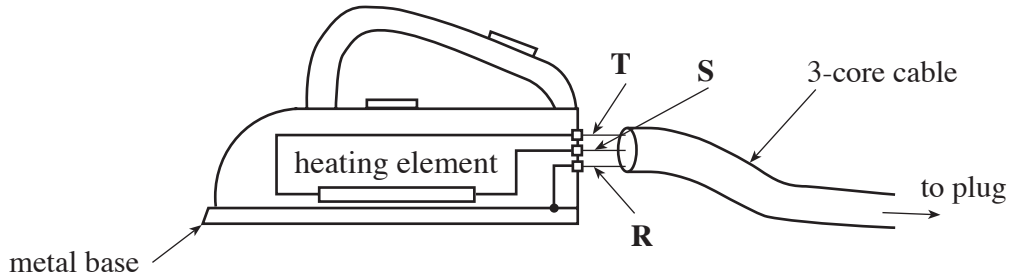

- (a) (i) Which wire, **R, S** or **T**, is the earth wire?
- (ii) State the colour of the plastic insulation covering the Earth wire. [2]
- (b) (i) The iron is marked 230 V, 750 W.

Write down in words an equation from page 2 and **use it** to calculate the current flowing through the heating element when it is working normally. [3]

Equation

.....

Calculation

Current = A

- (ii) State which size of fuse, 3 A, 5 A or 13 A, should be placed in the plug attached to the iron. [1]

.....

2. Some radioactive elements emit more than one type of radiation.

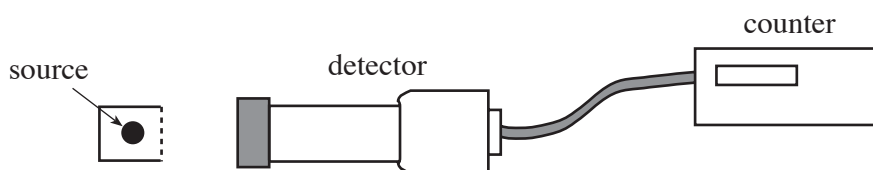

The above apparatus was used to investigate the radiation emitted from 3 sources, **A**, **B** and **C**. The sources were always placed at the same position, close to the detector.

The table below shows the mean counts per minute obtained when different materials were placed between the sources and the detector. All the readings have been corrected for background radiation.

Source	Mean counts / min with nothing between source and detector	Mean counts / min with thin paper in the way	Mean counts / min with 3 mm of aluminium in the way	Mean counts / min with 2 cm of lead in the way
A	256	256	256	85
B	135	80	80	0
C	310	310	188	0

- (a) Which source has the biggest detected activity when 3 mm of aluminium is placed between the source and the detector? [1]

.....

- (b) (i) How can you tell that source **A** is emitting gamma (γ) radiation? [1]

.....

- (ii) How can you tell that source **B** is **not** emitting beta (β) radiation? [1]

.....

.....

- (c) Which source, **A**, **B** or **C**, emits alpha (α) particles?
Give a reason for your answer. [2]

.....

.....

.....

3. A skydiver jumps from an aeroplane and free falls. The skydiver is acted on by the two forces shown.

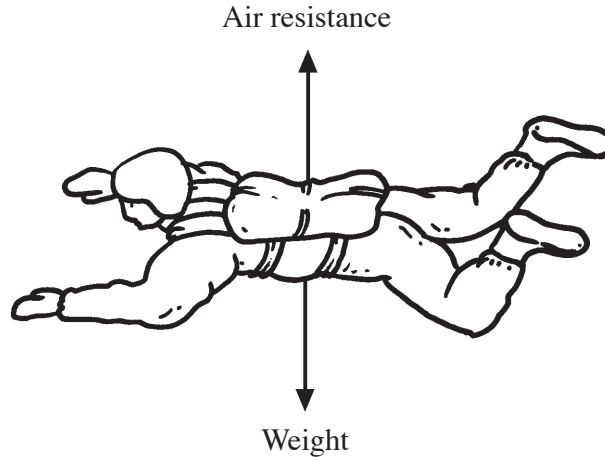

- (a) State what happens to **each of the forces** as the speed of the skydiver increases. [2]

.....

.....

.....

- (b) Explain why the skydiver eventually moves at a steady speed. [2]

.....

.....

.....

.....

- (c) Describe and explain what happens when the skydiver opens the parachute. [3]

.....

.....

.....

.....

4. The graph shows how the current depends upon the voltage for a torch bulb (**T**) and a long copper wire (**W**).

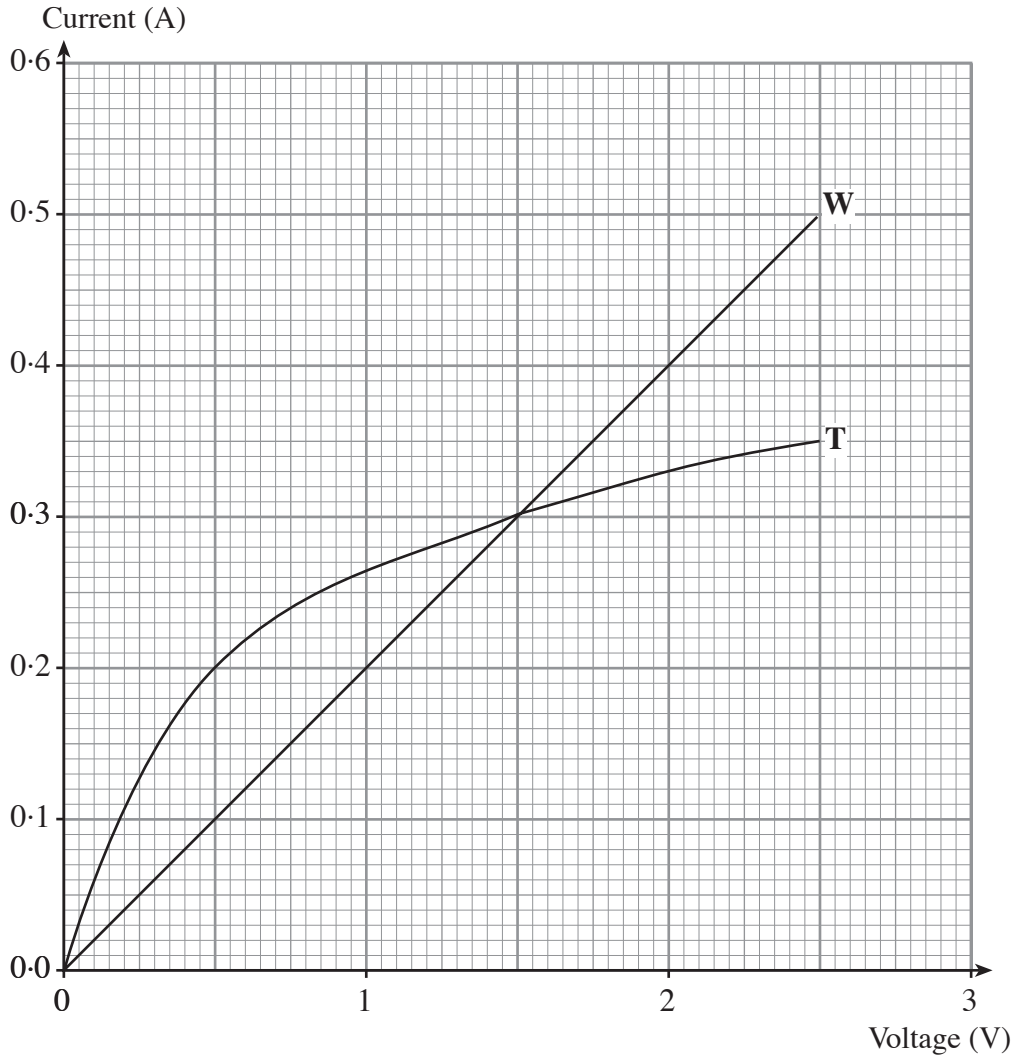

- (a) **Write down in words** an equation from page 2 and **use it** to calculate the resistance of the torch bulb when 0.2 A flows through it.

Equation [1]

.....

Calculation [2]

Resistance = Ω

- (b) The resistance of the wire is 5.0Ω . Use the graph to find the current through the torch bulb when the torch bulb has a resistance of 5.0Ω . [1]

Current = A

- (c) How does the resistance of the torch bulb compare with that of the wire when a voltage of 2 V is applied to them both? [1]

.....
.....

5

5. (a) Carbon-14 has a half life of 5700 years.
Draw a graph, on the grid below, to show the decay of carbon-14 from an initial activity of 64 counts / minute. [3]

Activity (counts / minute)

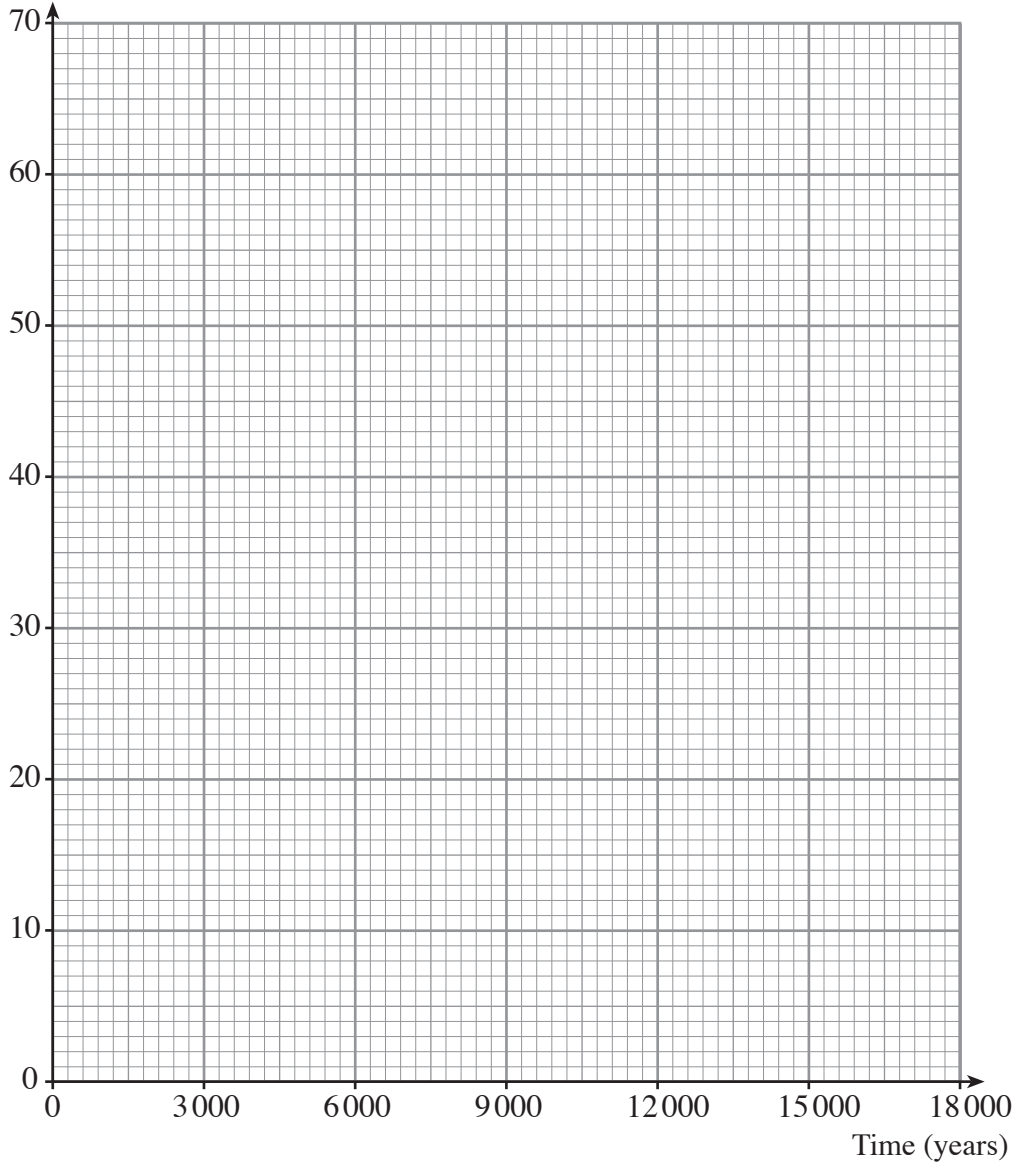

- (b) While trees are alive they absorb and emit carbon-14 (in the form of carbon dioxide) so that the amount of carbon-14 in them remains constant.

(i) What happens to the amount of carbon-14 in a tree after it dies? [1]

.....

- (ii) A sample of wood from an ancient dwelling gives 36 counts per minute. A similar sample of living wood has 64 counts per minute. From your graph, deduce the age of the dwelling.
(Show on your graph how you obtained your answer.) [2]

6. Fuses and circuit breakers are electrical safety devices used to protect household electrical circuits.

(i) Explain how fuses and miniature circuit breakers protect household electrical circuits. [2]

.....

.....

.....

(ii) State one way in which miniature circuit breakers are more effective than fuses. [1]

.....

(iii) Explain how the action of a residual current device is different from that of a miniature circuit breaker. [2]

.....

.....

.....

5

7. The diagram shows a winch at **Y** which is used to pull at yacht at **X** 50 m up the slipway through a vertical height of 4 m.

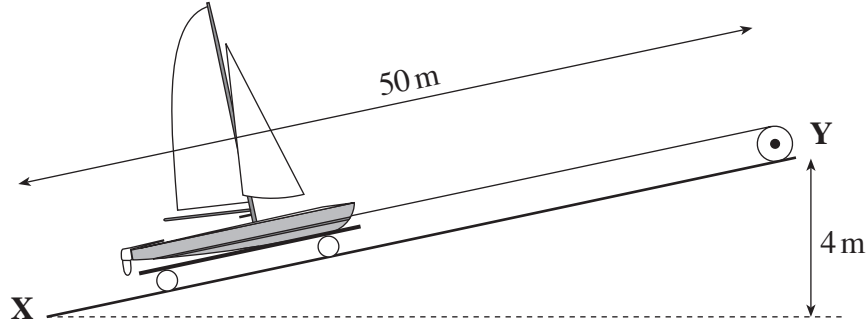

- (a) **Write down in words** an equation from page 2 and **use it** to calculate the gain in potential energy of the yacht when it is pulled to the top of the slipway.
[Mass of yacht = 1500 kg. Gravitational field strength = 10 N/kg]

Equation [1]

.....

Calculation [2]

Gain in potential energy = J

- (b) A frictional force of 1000 N acts on the yacht.

Write down in words an equation from page 2 and **use it** to calculate the work done against this frictional force.

Equation [1]

.....

Calculation [2]

Work done = J

- (c) (i) Hence calculate the **total** amount of work done by the winch in pulling the yacht up the slipway. [1]

Total work done = J

- (ii) Calculate the force that must be applied by the winch in pulling the yacht up the slipway. [2]

Force = N

9

TURN OVER FOR THE LAST QUESTION

8. (a) The following item appeared in a news report.

There has been a leak of radiation during the transfer of radioactive waste to a nuclear reprocessing plant. **The radiation was in the form of a gas.**
About 100 g of the gas Radon-222 escaped from a poorly sealed container.
Radon-222 is an α -emitter and has a half life of 52 seconds.
A spokesman stated that the leak was not dangerous **since the radiation becomes harmless after 104 seconds.**

The underlined parts are incorrect. State and explain what is wrong with them. [4]

.....
.....
.....
.....
.....
.....

(b) After reprocessing, radioactive waste is sealed in steel containers, which are stored with thick concrete shielding around them. Safe storage will be required for many hundreds of years.

(i) Explain why thick shielding is used to surround the steel containers.

.....
.....
.....

(ii) Explain why safe storage will be required for hundreds of years.

.....
.....
..... [3]

7